

# FONTAINE MAGNITUDE™ 55L LOWBED TRAILERS

FIND OUT WHY  
MORE FLEETS  
AND OWNER  
OPERATORS  
RUN WITH  
FONTAINE® THAN  
EVER BEFORE

Magnitude™



## Fontaine Magnitude 55L Lowbed

- THE MOST VERSATILE HYDRAULIC REMOVABLE GOOSENECK IN THE INDUSTRY
- 18" LOADED DECK HEIGHT WITH 6" GROUND CLEARANCE GIVES YOU A RUGGED LOW PROFILE
- TRUE 55 TON CAPACITY IN 16' TO HANDLE HEAVY LOADS
- 96" OR 108" SWING RADIUS WITH 12' 6" GOOSENECK LENGTH
- 25' CLEAR DECK LENGTH GIVES YOU ALL THE ROOM YOU NEED
- 5-POSITION ADJUSTABLE RIDE HEIGHT FOR USE WITH A WIDE RANGE OF FIFTH WHEEL HEIGHTS OR DIFFERENT DECK HEIGHTS
- SMOOTH UNITIZED AIR-RIDE SUSPENSION WITH AUTOMATIC AND MANUAL CONTROLS

*When you're ready to move up to the best lowbed trailer in the industry, we're ready to deliver. Fontaine Magnitude™ trailers are engineered and built to handle the toughest jobs with ease. And when you get to your destination, the most versatile gooseneck in the industry makes loading and unloading a breeze.*



WWW.FONTAINETRAILER.COM

# MAGNITUDE™ 55L LOWBED SPECIFICATIONS

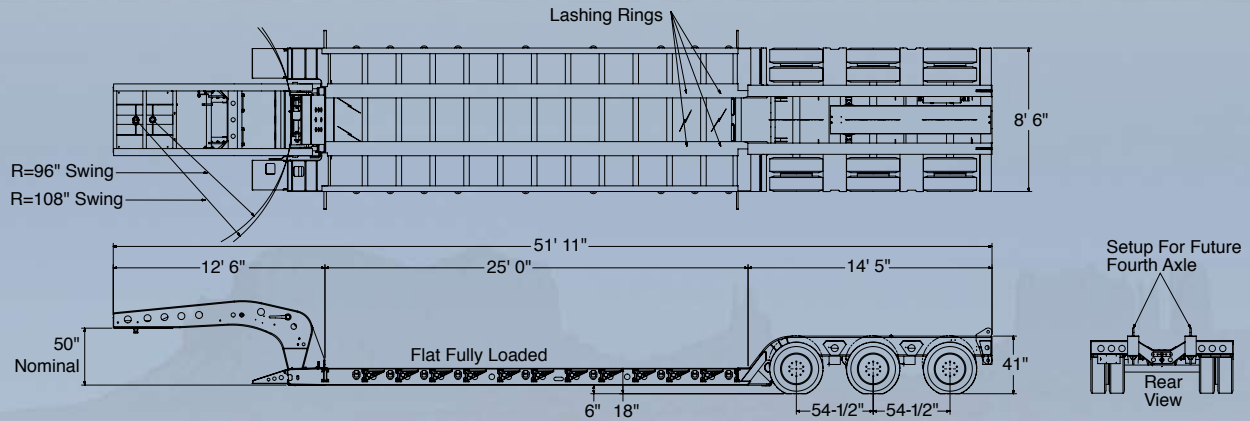

## MAIN BEAMS

- All main longitudinal members fabricated with 100 KSI minimum yield steel flanges with 50,000 lb webs

## CAPACITY

- 55 tons in 16' length with fourth axle close coupled—GAWR and tire ratings determine legal payloads

## LOAD BASE

- 16' rigid 2-point load centered in deck

## DIMENSIONS

- Overall: 8' 6" width x 51' 11" length
- Clear deck length: 25', flat level design
- Deck height under full load: 18" (ground clearance: 6")
- 50" nominal loaded fifth wheel height with 5 ride height positions
- Rear bogie height: 41"

## GOOSENECK DESIGN

- Hydraulic, removable, non ground bearing, set up for wet line
- Adjustable ride height features 5-position mechanical lock for separate deck and fifth wheel height control
- 96" or 108" swing radius (12' 6" overall gooseneck length)
- J560 7-pin electrical connector

## DECK DESIGN

- Front flip ramps make loading and unloading easier
- 2" nominal apitong flooring (side rails only)
- Expanded metal in first full deck compartment for tool storage
- Last three crossmembers in deck recessed with expanded metal for additional storage area between crossmembers
- 12 pair (24 total) removable swing-type extension brackets
- 1 pair (2 total) hook-on type extension brackets

## BOGIE DESIGN

- Fixed deck-to-bogie connection with front bogie ramp
- V-style boom trough with bolt-in pan
- Recessed load bearing bolsters between axles and behind last axle
- Mechanical ride height control valve (Whittle style)
- Heavy-duty V-style rear bumper
- Air/electrical connections in place for easy fourth axle connection

## AXLES

- 2 heavy-duty axles with 54 1/2" spread
- 25,000 lb nominal capacity per axle
- Tapered spindle axles, automatic slack adjusters and drum brakes
- 1 set of mudflaps

## BRAKES

- 16 1/2" x 7" with 5 1/2" autoslacks (2 axles)
- Heavy-duty brake drums, outboard mount
- Quick change replacement feature saves repair time
- Automatic slack adjusters maintain positive braking action

## HUBS

- Hub-piloted 10-stud mount for increased capacity and durability
- Outboard cast drums save time and cost on brake repairs

## WHEELS/TIRES

- 8.25 x 22.5 steel disc wheels with 275/70R 22.5 H-ply tires

## SUSPENSION

- Unitized air-ride suspension with automatic and manual controls
- Suspension mount is engineered, reinforced and braced to virtually eliminate frame cracking

## ELECTRICAL SYSTEM

- Sealed harness for maximum corrosion resistance
- DOT sealed beam and harness with LED lights and 4" LED beacon strobe—flush mounted with battery back up
  - Marker lights and mid-turn signals
  - 3 stop, tail and turn lights per side on rear

## PROTECTIVE COATING

- Highest quality 2-part polyurethane enamel fights corrosion to extend the life of your trailer
  - Shot blasted and cleaned prior to painting
  - Primed for better paint adhesion

## LASH RINGS

- 9 pair (18 total), bent design provides chain clearance over siderail
- 2 pair (4 total) inboard of deck main beams at last two compartments

## FLAG HOLDERS

- 2 pair (4 total)

## ESTIMATED EMPTY WEIGHT

W/O OPTIONS: 21,575 lbs ± 3%

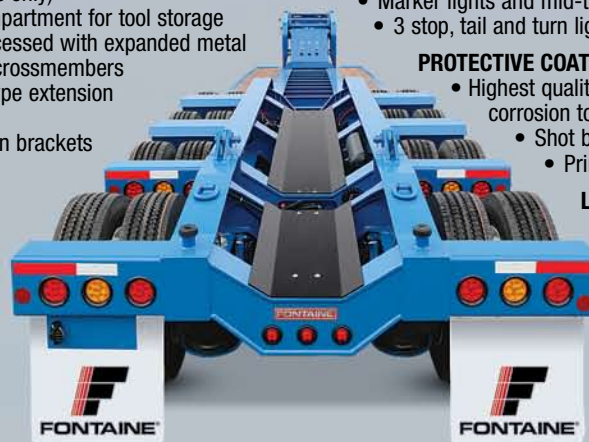

Specifications subject to change without notice.

Photos show some optional equipment.



Fontaine Trailer Company

430 Letson Road • Haleyville, AL 35565 • 800-821-6535 • fax 205-486-8985 • www.fontainetrailer.com